

Data Sheet

BP2815 - 12v 150Ah Lithium Ion Battery Module

| | |
|--------------------|-------------------------------------|
| Product Name | Lithium Ion (Li-ion) Battery Module |
| Battery Model Spec | Li-ion - 18650 3S57P 10.8V 150Ah |
| File Revision | A0 |

Amendment Records

| Revision | Description | Issued Date |
|----------|-------------------|-------------|
| A0 | Original document | 2019-01-15 |

1 Scope

This document describes the performance characteristics and testing methods for Li-ion batteries produced by Tracer Power, a division of Cell Pack Solutions Ltd.

2 Product type and model number

2.1 Product type

Lithium Ion Battery Module

2.2 Model number

BP2815 - Li-ion 18650 3S57P 10.8V 150Ah

3 Rated performance

Table 1: Rated Performance

| # | Item | Rated performance | Remark |
|----|----------------------------------|--|--|
| 1 | Nominal capacity | 150Ah±5% | Standard discharge after standard charge |
| 2 | Nominal voltage | 12V | |
| 3 | Actual voltage | 10.8V | |
| 4 | Voltage at end of discharge | 8.25V | Discharge cut-off voltage set by BMS |
| 5 | Charging voltage | 12.6V | |
| 6 | Standard charge current | Constant current: 10A Constant voltage: 12.6V Cut-off current: ≤ 0.02C | |
| 7 | Maximum charge current | Constant current: 20A Constant voltage: 12.6V Cut-off current: ≤ 0.02C | |
| 8 | Standard discharge current | 10A | |
| 9 | Maximum discharge current | 20A | |
| 10 | Peak discharge current | 50A | For 10ms |
| 11 | Impedance | < 120mΩ | |
| 12 | Equivalent Lithium Content (ELC) | 135g | |
| 13 | Shipping charge state | ≤ 30% | |
| 14 | Operation temperature range | Charge: 0~45°C Discharge: -10~60°C | 60±25% R.H |
| 15 | Cycle life | > 500 cycles | Charging/discharging in the below condition: Charge: standard charge Discharge: standard discharge to 8.25V Rest time between charge/discharge: 30min Until the discharge capacity < 70% of NC |
| 16 | Storage temperature | ≤1 month: -10~45°C ≤3 months: -10~35°C ≤1 year: 0~25°C | 60±25% R.H Best: 10~25°C for long-time storage |
| 17 | Weight | Approx: 9kg | |
| 18 | Module Dimensions | 242 x 310 x 73 mm | |

4 Supplied items

- Tracer 12V 150Ah Li-ion Battery Module
- Tracer Battery 5-LED Fuel Gauge (TR8300)
- Tracer CH2F Female Chassis Socket (TR8308)
- Tracer 12V Cigarette Lighter Chassis Socket (TR8309)
- Tracer Terminal Posts (x2) with Eyelets (TR8310)

5 Battery module features

- Output wiring (BMS rated to 20A) with 14 AWG wiring
- 12V cigarette lighter socket (rated to 10A) with 14 AWG wiring
- Charge socket (BMS rated to 20A) with 14 AWG wiring
- Fuel Gauge - 5 colour LED fuel gauge to show charge level

6 Electrical performances

6.1 **Table 2: Battery Electrical Performances**

| # | Items | Test procedure | Requirements |
|---|-----------------------|--|---|
| 1 | Voltage | The average value of the working voltage during the whole discharge process. | 10.8V |
| 2 | Discharge performance | The discharge capacity of the battery, measured with standard discharge down to 8.25V within 1 hour after a standard charge at 25±5°C | Discharge capacity ≥ Minimum capacity |
| 3 | Capacity retention | After 28 days storage at 25±5°C, after having been standard charged and standard discharged to 8.25V | Capacity is above 90% of nominal capacity |
| 4 | Cycle life | Charging/discharging in the below condition: Charge: standard charge at 25±5°C Discharge: 0.5C to 8.25V Rest time between charge/discharge: 30min Until the discharge capacity < 70% of nominal capacity | > 500 cycles |
| 5 | Storage | Within 3 months of manufacture the battery is charged with standard charge to 40-50% capacity and stored at ambient temperature 25±5°C, 65±20% RH for 12 months. After the 12 months storage period, the battery is standard charged and standard discharged to 8.25V | Capacity is above 80% of nominal capacity |

6.2 Discharge Voltage

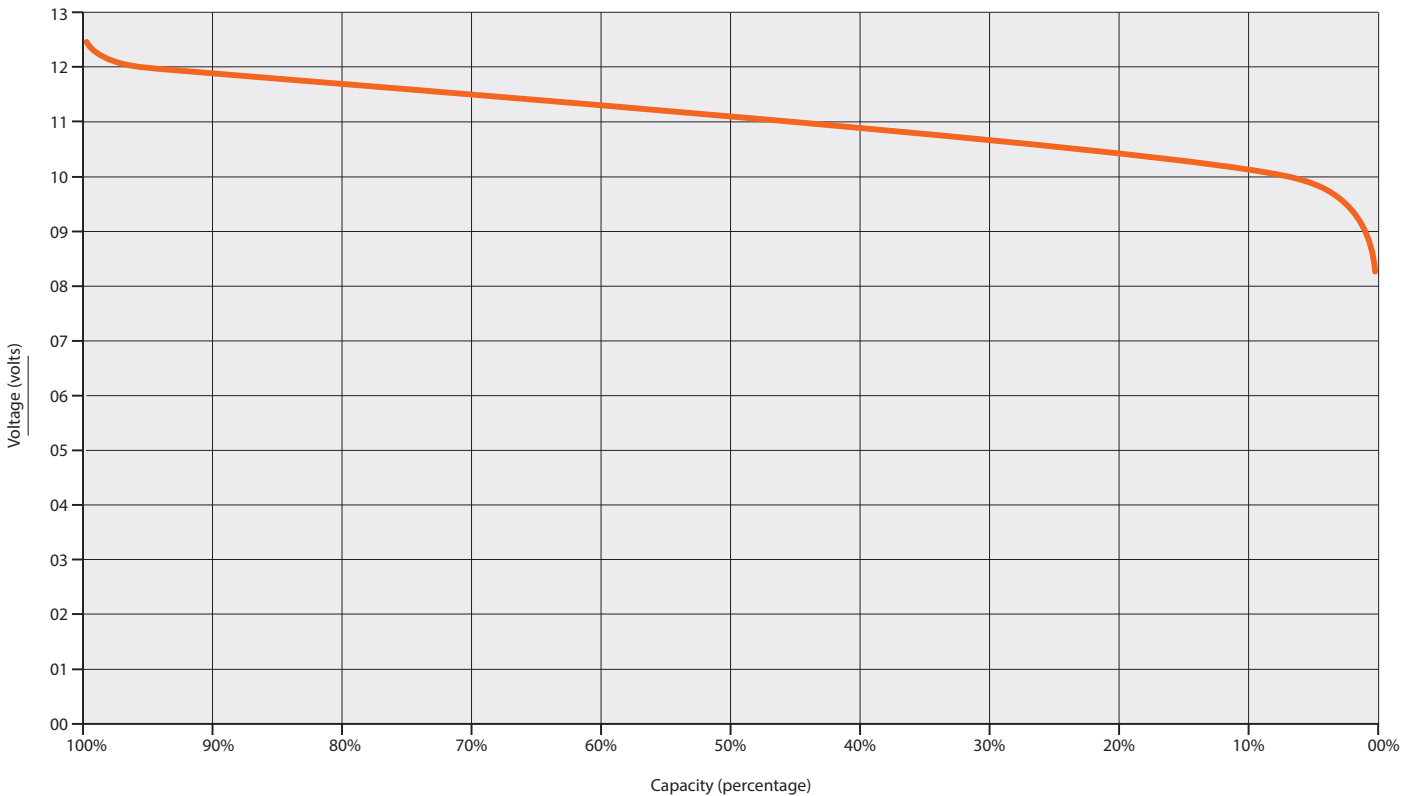

6.3 Built-in protection

- Overcharge
- Deep-discharge
- Over-temperature
- Over-current
- Short circuit

6.4 Circuit diagram

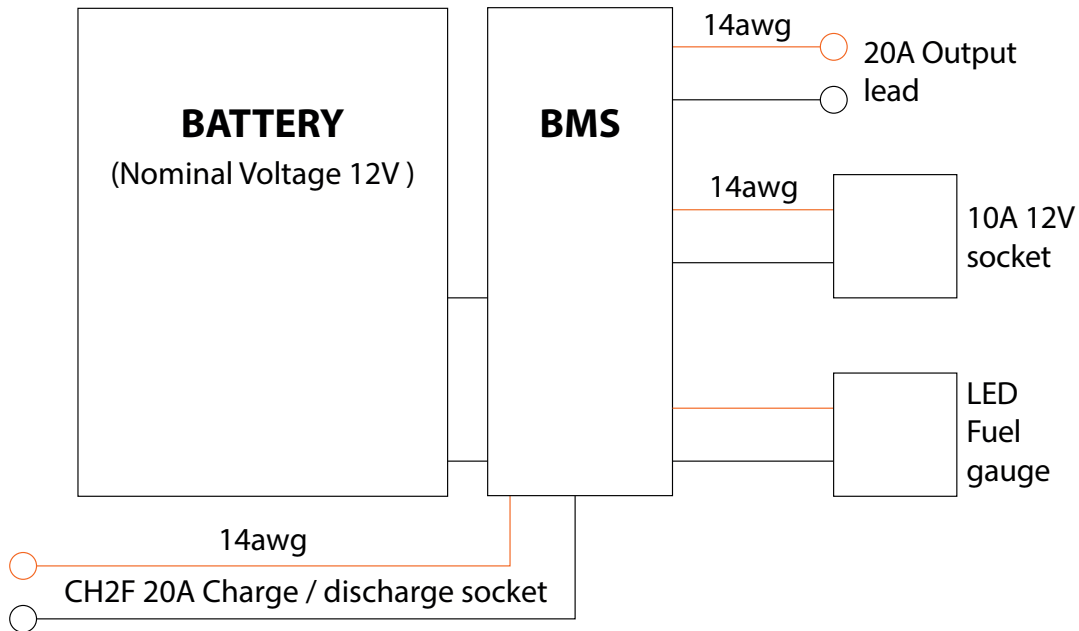

7 Fuel gauge specifications

Fuel Gauge - 5 colour LED Status:

- | | |
|------------------|------------------------|
| 3 green & 2 red: | Battery fully charged |
| 2 green & 2 red: | Less than 80% capacity |
| 1 green & 2 red: | Less than 65% capacity |
| 2 red: | Less than 30% capacity |
| 1 red: | Less than 10% capacity |
| No lights: | Battery empty |

8 Standard test conditions

Any tests are to be conducted with new batteries that have not been cycled more than five times before the test. Unless otherwise defined, test and measurements done under a temperature of 20±5°C and relative humidity of 45~85%. If it is judged that the test results are not affected by such conditions, the tests may be conducted at temperature 15~30°C and humidity 25~85% RH.

9 Cautions in use

To ensure proper use of the battery please read the manual carefully before using it.

9.1 Handling

- Do not expose to, or dispose of the battery in fire.
- Do not put the battery in a charger or equipment with wrong terminals connected.
- Avoid short-circuiting the battery.
- Avoid excessive physical shock or vibration.
- Do not disassemble or deform the battery.
- Do not immerse in water.
- Do not use the battery mixed with other different make, type, or model batteries.
- Keep out of the reach of children.

9.2 Charge and discharge

- Battery must be charged with an appropriate charger only.
- Never use a modified or damaged charger.
- Do not leave the battery in a discharged state for over 24 hours.

9.3 Storage

Store the battery in a cool, dry area out of direct sunlight.

9.4 Disposal

Regulations vary for different countries, dispose of in accordance with local regulations.
Dispose of responsibly by contacting your local refuse centre.

10 Battery operation instruction

10.1 Charging

Charging current: Must not surpass the highest charging current which is specified within Table 1.
Charging voltage: Must be regulated to the charging voltage specified within Table 1.
Charging temperature: The battery must be charged in the ambient temperature scope in Table 1.
Use constant electric current and constant voltage to charge.
Do not reverse charge.
It is recommended to only use Tracer dedicated chargers.

10.2 Discharging current

The discharge current must not surpass the highest discharge current specified in Table 1.
An oversized discharge current can cause the battery's nominal capacity to reduce and the battery to overheat.

10.3 Discharging temperature

The battery must be discharged in the ambient temperature scope specified in Table 1.

10.4 Over-discharge

When excessively discharged the battery should always be charged immediately after use to ensure the battery maintains nominal capacity and does not deteriorate.

10.5 Storing the batteries

The battery should always be stored in conditions as specified in Table 1.
If the battery is left unused for a period longer than 6 months it should be placed on charge.

11 Period of warranty

Tracer Li-ion batteries are covered by a one year limited warranty. The warranty covers premature failure due to defects in materials and/or workmanship. Any breakage caused by accidental damage or as a result of abuse or misuse is not covered. The warranty is limited to the original purchaser and is not transferable.
The warranty is void if the serial number is removed from the product or if the battery has been modified in any way. Please charge your battery directly after each use. Leaving your battery in discharged state will seriously and permanently damage its performance. Please note we cannot uphold warranty claims in these circumstances. Your battery will degrade over time and with use, such degradation is not covered by warranty.

12 Other - Chemical reaction

Because batteries utilise a chemical reaction, battery performance will deteriorate over time even if stored for a long period of time without being used. In addition, if the various usage conditions such as charge, discharge, ambient temperature, etc. are not maintained within the specified ranges, the life expectancy of the battery may be shortened or the device in which the battery is used may be damaged by electrolyte leakage. If the batteries cannot maintain a charge for long periods of time, even when they are charged correctly, this may indicate it is time to change the battery.

13 Note

Any other items which are not covered in this specification shall be agreed by both parties.